

THE RED BARON'S

Fokker Dr. 1

R77 PM-001



The photo depicts the test prototype. Some details of the actual model may be slightly different.

★ **DIFFICULTY**
DIFICULTAD ★★☆☆☆
2/5 - Simple

■ **SCALE** **1:33**
ESCALA (approx.)

🖨️ **PRINT** Letter & A4
IMPRIMIR compatible

✂️ **# OF PARTS** **16**
DE PARTES

↕️ **SIZE** 21X17 cm
TAMAÑO 8X6,5 in.

T **INSTRUCTIONS** English
INSTRUCCIONES Español

THE RED BARON'S FOKKER Dr.1

© 2010, 2011 Rubén Andrés Martínez Arias.

This is an exclusive download only from: <http://www.papermodelers.com> and <http://rubenandres77.deviantart.com>

Made in Bogotá, Colombia.





*for my parents
who gave me my first Dreidecker*

THE RED BARON'S FOKKER DR.1

a paper model by Rubén Andrés Martínez Arias



R77 PM-001

© 2010-2011 by Rubén Andrés Martínez Arias
Originally released on November 12, 2010, exclusively at:
<http://www.papermodelers.com> and <http://rubenandres77.deviantart.com>

This revised and corrected second release (June 2011)
replaces the previous one which should no longer be distributed.

**This paper model of the Fokker Dr.1 is a free download available only from:
<http://www.papermodelers.com> and <http://rubenandres77.deviantart.com>**

**If you paid to get this file, or you obtained it
from a place different to the ones mentioned above
you were victim of fraud,
and the security of your computer may be compromised.**

Please visit the sites above to get an official, licensed, and risk-free copy of it at no cost.

End User License Agreement

This is a legal and binding agreement ("End User License Agreement") between you (the user of this kit) and Rubén Andrés Martínez/R77 Paper Models. By downloading or viewing this electronic kit you consent to agree and to be bound by this License.

1. Use

You are allowed to use this electronic kit in the way, and under the terms expressed in this agreement.

Rubén Andrés Martínez/R77 Paper Models hereby grants you a non-exclusive, nontransferable license to download this PDF file containing the kit to build a paper model, to use it internally on a single computer, print out the complete file or single pages of it solely for your personal use, and use said printed copy(ies) of the kit solely for your personal use, according to the terms and conditions of this agreement. All rights not expressly granted herein are retained by Rubén Andrés Martínez/R77 Paper Models and its licensors, as the case may be.

2. Limitations

You can print as many physical copies as you need, as long as they are used for personal paper modeling purposes, and not used in any other way. You may make a reasonable number of copies and prints of the kit for personal backup or personal

Licencia de Acuerdo del Usuario Final

Este es un acuerdo legal y de obligaciones (Licencia de Acuerdo del usuario Final) entre usted (el usuario) y Rubén Andrés Martínez/R77 Paper Models. Al descargar o revisar este kit electrónico usted consiente a seguir y comprometerse con los términos de esta Licencia.

1. Uso

Usted está autorizado a usar este kit electrónico en la manera y bajo las condiciones expresadas en este acuerdo.

Al descargar este archivo PDF que contiene un kit para armar un modelo de papel, Rubén Andrés Martínez/R77 Paper Models le concede aquí una licencia no exclusiva e intransferible para que lo use internamente en un computador, imprima el kit completo, o páginas de él, solo para uso personal, y a usar dicho material impreso proveniente del kit electrónico sólo para uso personal, de acuerdo a los términos y condiciones contenidas en esta licencia. Todos los derechos no concedidos expresamente aquí son y se mantienen propiedad de Rubén Andrés Martínez/R77 Paper Models y/o sus licenciatarios si es el caso.

2. Limitaciones

Puede imprimir tantas copias físicas como necesite, siempre y cuando sean usadas para propósitos personales de modelado en papel, y no usados de otra manera. Puede hacer una cantidad razonable de copias e impresiones del kit únicamente para preservación personal de archivos, siempre y cuando el archivo





archival purposes only, as long as the file remains intact in its original form with all its components, including texts, copyright notice, and this license. You shall not, and shall not permit a third party to remove any identification, copyright or other notice from the files.

You are only allowed to use this kit for building a paper model of the Fokker Dr.1. You are not allowed to edit, modify, convert, translate, re-format, decompile, export to other digital or physical formats, transform or reverse-engineer this kit or parts of it. You cannot use this kit or parts of it as a basis for other derivative works.

This kit (or parts of it) can not be copied, sold, rented, leased, gifted, distributed, sublicensed, assigned, loaned, time-shared, shared, transmitted through a computer network or in any form or by any means of storage and retrieval system now known or to be invented without the express written authorization of Rubén Andrés Martínez/R77 Paper Models.

Any distribution of the files, including distribution without monetary gain by any physical, electronic, digital, archival or file retrieving medium is an infringement of the present conditions of this license.

You are not allowed to sell, rent, lease, give, distribute, share, or use digital or printed copies of this file for commercial purposes, or involving direct or indirect monetary gain for you or for third parties in any way, in any place, event, website, or computer network.

3. Ownership

This license grants you the right to use this kit in the manner and under the limitations described in this license, but does not grant you any intellectual rights on it.

This kit to build a paper model of the Fokker Dr.1 is protected by international copyright laws and international treaties. All the contents including texts, graphics, photographs, distinctive images, representative design and layout elements and the specific design of the parts of the model are owned by Rubén Andrés Martínez/R77 Paper Models and are protected worldwide by copyright laws and must not be used without direct express written permission.

Rubén Andrés Martínez/R77 Paper Models reserves the right to edit, modify or change the kit or parts of it with or without previous notice. Rubén Andrés Martínez/R77 Paper Models also reserves the right to re-release, re-distribute, or stop the distribution of this kit, or parts of it, or to release it in other ways or formats or under other conditions at any given time, with or without prior notification.

All commercial, as well as any educational or non-commercial use of the kit must be previously consulted with Rubén Andrés Martínez/R77 Paper Models.

4. Termination

This license is effective until terminated. It will terminate immediately without notice if you fail to comply with any of the conditions stated herein. Upon termination you shall destroy all digital and physical copies of the kit or parts of it.

5. Inquiries.

For any inquiries, requests, information, etc., please write to: Rubén Andrés Martínez Arias ruben77@gmail.com

© 2010, 2011
by Rubén Andrés Martínez/R77 Paper Models

permanezca intacto en su forma original con todos sus componentes, incluyendo textos, notificación de derechos de autor (copyright), y esta licencia. Usted no puede, y no permitirá a un tercero, remover cualquier identificación, notificación de derechos, u otros textos identificativos de estos archivos.

Usted está autorizado solamente a usar este kit para construir modelos de papel del Fokker Dr.1. Usted no está autorizado a editar, modificar, convertir, traducir, re-formatear, descompilar, exportar a otros formatos físicos o digitales, transformar, o hacer ingeniería reversa con este kit completo o en parte. No puede usar este kit como base para crear trabajos derivados.

Este kit (o partes del mismo) no puede ser copiado, vendido, rentado, regalado, distribuido, sublicenciado, asignado, prestado, compartido, transmitido a través de una red de computadores o por cualquier forma o medio de almacenamiento o recuperación de archivos conocidos ahora o por inventar, sin la autorización expresa y por escrito de Rubén Andrés Martínez/R77 Paper Models.

Cualquier distribución del archivo, incluyendo distribución sin ganancia económica, por cualquier medio físico, electrónico, digital, archivístico, de recuperación de información es una contravención a las condiciones presentes en esta licencia.

Usted no está autorizado a vender, rentar, regular, distribuir, compartir, o usar copias digitales o impresas de este archivo para propósitos comerciales, o que involucren una ganancia de dinero para usted o para un tercero de ninguna manera, en ningún evento, lugar, sitio web, o red de computadores.

3. Propiedad

Esta licencia le otorga al usuario el derecho de uso del kit en la manera y con las limitaciones descritas en esta licencia, pero no le otorga la propiedad intelectual sobre el mismo.

Este kit para construir un modelo de papel del Fokker Dr.1 está protegido por leyes internacionales de Derechos de Autor y por tratados internacionales. Todo el contenido, incluyendo textos, gráficos, fotografías, imágenes distintivas, elementos de diseño y diagramación representativos y el diseño específico de las partes del modelo son propiedad de Rubén Andrés Martínez/R77 Paper Models y están protegidos globalmente por las leyes de derechos de autor y no pueden ser usados sin autorización directa y expresa por escrito.

Rubén Andrés Martínez/R77 Paper Models se reserva el derecho de editar, modificar, o cambiar el kit o partes del mismo sin aviso previo. También se reserva el derecho de re-publicar, re-distribuir, o de suspender la distribución del kit o de partes del mismo, o de publicarlo de otras maneras, en otros formatos, o bajo otras condiciones en cualquier momento, con o sin notificación previa.

Todo uso tanto comercial como educacional de este kit debe ser consultado previamente con Rubén Andrés Martínez/R77 Paper Models.

4. Terminación

Esta licencia es efectiva hasta el momento de su terminación. Terminará inmediatamente y sin aviso cuando usted falte al cumplimiento de cualquiera de las condiciones establecidas aquí. A su terminación, usted debe destruir todas las copias digitales y físicas que haya hecho del kit o de partes del mismo.

5. Información.

Para peticiones, permisos, información, etc., por favor escriba a: Rubén Andrés Martínez Arias ruben77@gmail.com

© 2010, 2011
por Rubén Andrés Martínez/R77 Paper Models





Please read carefully this page and follow the instructions given here before printing any page of this electronic kit. It will save you time, paper, and ink.

The size and layout of this kit:

This kit is presented in A4 paper size (21 X 29.7 cm / 8.3 × 11.7 in). However, the layout and placement of the parts has been prepared to fit safely in sheets of paper of both A4 and Letter sizes.

This means that you can use Letter size paper to print all the pages of this kit, without risk of losing anything, and without scaling the parts. Letter size measures 21.6 × 27.9 cm (8.5 × 11 in). It is a bit wider than A4 (by 7mm, or ¼ in), but it is also a bit shorter (18mm, or ¾ in).

Test your printer:

To make sure that you will print properly all the pages at the correct scale, and that no part of the kit will be cropped, first make a test printing *this same page (page #4)*.

The red borders in this page represent the area of the pages where parts are located. If you print this page and can see the red borders, then there will be no problems when printing the rest of the kit.

To make the print test, do the following:

1. Choose “print” from the file menu”
2. Choose the paper size you are feeding to the printer.
3. Set “page scaling” to “none”.
4. Disable the “Center on page” (or similar) option.
5. Print.

Step # 3 is very important, because if you want to print the kit at its original scale, the page needs to be sent at 100% (no page scaling).

If you choose “fit to page”, “shrink to printable area” (or a similar setting) in step#3, the pages will be sent at a smaller scale. You will surely see the four red borders. However, the final model will be a few millimeters smaller than the intended original scale. Set this option to “none”, or “don't fit to page” to have the real size/scale.

If you are using Letter size also make sure that you disable “center on page”. If the page is sent centered to the printer the top margin of the page will be lost. Turn off the “center on page” option to ensure a correct print of the page.

Note about the white safe borders:

The white safe borders of the pages may vary and the red borders may not show in some cases depending on the model of the printer you are using. With some printers, the white safe borders will be smaller, and you'll see the red rectangle without needing to adjust anything. All printer brands have different safety borders, and some can even disable the safety margins. If you don't see the four sides of the red rectangle in this page, then adjust your printer settings until the printable borders are tuned. Refer to your own printer's manual and technical information to adjust it.

Using Legal size paper to solve fitting problems:

If you still can't see the four red borders, you can solve this problem by using Legal size paper. Legal size (21,6 cm X 35,6 cm, or 8.15 in X 14 in) is a bit wider and noticeably longer than A4. Using Legal size, and following the above steps will surely result in a safe print of the whole page. If you use Legal size, then you can safely use the “center on page” option to preserve the top and bottom borders.

To confirm the correct size of the printed page, compare the ruler provided in this page with a ruler or a metric scale. They must coincide.

Once you get a successful print test, make sure you print all the pages using exactly the same settings.

Important note on colours:

Different computer monitors and different printers/inks can display different tones/hues of colour depending on the particular settings of each machine.

To check/adjust the accurate tones of the colours you can use your printer's test page or the colour table provided below.

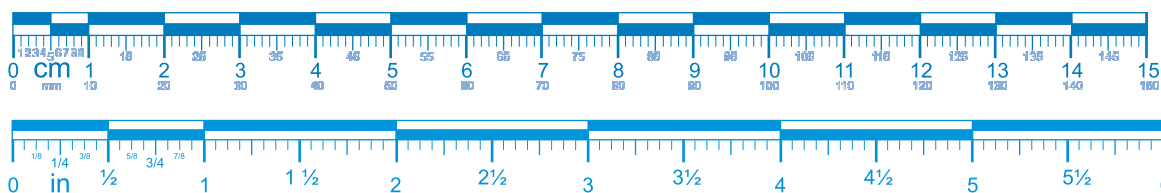
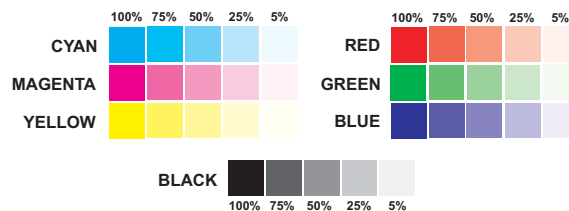



Contents

Before printing any page of the kit:

Don't forget to make a test print of page # 4 and adjust your printer according to the instructions given.

Read carefully the table of contents below to get familiar with the contents of the kit, and to print only the pages you want. This kit has 20 pages, including the 4 pages of parts to build the model. If you prefer to save paper you can print only the pages with parts, and read the instructions from the screen.

Each page is numbered. The table also guides you on what paper is best for each section. Study this table and get familiar with the pages of the kit before printing, and to choose the appropriate kind of paper for each page. For pages indicated "print on paper" use regular paper (75 gms, or similar). This kind of paper is recommended for the instructions and information pages, as well as for the parts with interior details and smaller pieces. It is recommended that you use cardstock (between 160-200 gms, or similar) for structural parts and surfaces.

PAGE #	CONTENTS	PRINT ON
1	Cover	Paper
2, 3	Credits, copyright information, and release history	Paper
4	Printing guide	Paper
5	Table of contents	Paper
6	About this kit	Paper
7, 8	The Fokker Dr.1	Paper
9	Details about the scale of this paper model	Paper
10, 11	General instructions for paper model construction	Paper
12 – 16	Detailed instructions to build this model	Paper
17 – 20	Parts to build the Red Baron's Fokker Dr.1	Cardstock

Paper weight:

Paper characteristics may vary around the globe. Use this charts to choose a proper kind of paper suitable for you. If you don't have the exact paper cited here, you can use a close equivalent.

REGULAR (COPY) PAPER

weight	equivalents
75 gms	Bond 20 Index 40 Cover 28 Bristol 34

CARDSTOCK

weight	equivalents
160 gms	Bond 43 Index 90 Cover 60 Bristol 75

CARDSTOCK

weight	equivalents
200 gms	Bond 54 Index 110 Cover 75 Bristol 90



About This Kit

This is a very simple kit to build a paper model of the Red Baron's Fokker Dr.1. It only has 16 parts, and is not very detailed. Some parts of the plane may not be accurate if compared to the real plane. It is intended for beginners, or people with very little knowledge of paper modeling. The model is very easy to build, and by following the instructions you will spend very little time building it.

This model is inspired in a kit I received from my parents as a gift when I was 8 years old. It was my first paper model ever. When designing this paper model I wanted the 8-year old me (or actually, any little kid nowadays) to look at it as if it were an open and friendly door to the world of paper modeling/crafting. Just like that first paper model was for me in 1985. Maybe this will be some kid's first model, and will inspire him/her to follow the path of the paper. You can read the whole story of the design process here:

<http://www.papermodelers.com/forum/design-threads/10356-my-own-very-simple-red-barons-fokker-dr-1-a.html>

Given its simplicity this will probably be considered closer to a "paper toy" than to a "paper model". However, I'll be more than glad if anyone finds it interesting, or at least useful to spend a nice afternoon. For me, it has been pretty satisfactory, and that's all I wanted. And the 8-years old me is very happy indeed.

The kit was originally released on November 12, 2010. However, there were some flaws that I didn't correct at that time. This new version of the kit corrects the several issues it had, and offers a new colouring of the model making it more attractive. Instructions have been greatly improved, and it also offers a completely new presentation of the pages. This is the definitive version of the kit I intended from the beginning.

Rubén Andrés Martínez Arias
Bogotá D.C.
June 01, 2011

Este es un kit para armar un modelo de papel muy simple del Fokker Dr.1 del Barón Rojo. Sólo consta de 16 partes, y no es muy detallado. Algunas partes del avión podrían no ser exactas si se comparan con el avión real. Está pensado para principiantes, o para personas con muy poco conocimiento de modelismo en papel. El modelo es muy fácil de armar, y siguiendo las instrucciones usará poco tiempo en su ensamble.

Este modelo está inspirado en un kit que recibí como regalo de mis padres a la edad de 8 años. Fue mi primera maqueta de papel. Al diseñar este modelo de papel, quería que el niño de 8 años que fui (o de hecho, cualquier niño actualmente) pudiera verlo como una puerta amigable al mundo del modelismo en papel. Justo como ese primer modelo de papel significó para mí en 1985. Quizás este sea el primer modelo de algún niño, y lo inspire a seguir el camino del papel. La historia completa del proceso de diseño aquí se puede leer en:

<http://www.papermodelers.com/forum/design-threads/10356-my-own-very-simple-red-barons-fokker-dr-1-a.html>

Dada su simplicidad, este podría considerarse más cercano a un "juguete de papel" que a una "maqueta de papel". Sin embargo, estaré complacido si alguien lo encuentra interesante, o al menos puede usarlo para pasar una tarde agradable. Para mí, ha sido satisfactorio desarrollarlo, y es lo que buscaba. Y el yo de 8 años está ciertamente muy feliz.

El kit se publicó originalmente en noviembre 12 de 2010. Sin embargo, tenía fallas que no fueron corregidas entonces. Esta nueva versión corrige todas las fallas, y ofrece además un nuevo trabajo de color más atractivo. Las instrucciones se han mejorado, y también se rediseñó la presentación de las páginas. Esta es la versión definitiva del kit que quería diseñar desde el principio.

Rubén Andrés Martínez Arias
Bogotá D.C.
Junio 01, 2011





The Red Baron's Fokker Dr. 1



Of the many aircraft that took part in the WWI, the Fokker Dr.1 was one of the most famous. It was not the only German plane, and it certainly was not the best of the airplanes during the conflict, but it came to be famous thanks to one man who became legend: Manfred von Richthofen, better known as “The Red Baron”.

The production of the Dr.1 started on mid-1917 when the necessity to fight the British Sopwith triplane led Germany to look for new and better planes. After several prototypes and tests marked with problems, Reinhold Platz came with a new design that incorporated innovative technologies and promised to fulfill the task. When in August 1917 the Fokker factory delivered the first prototypes of this plane for combat tests, Richthofen stated it was better than the Sopwith and recommended it to be used by the German Luftstreitkräfte.

However, the Dr.1 was far from perfect: given the use of a rotary engine, the Dr.1 was unstable on flight, and the maneuverability was always a matter of debate. Richthofen himself said about the plane: *“it climbed like a monkey, and maneuvered like the devil.”*

Some performance and design deficiencies led production of the Dr.1 to stop. Only 320 were built. Eventually, the new Fokker D.VII replaced the Dr.1 as the best German fighter.

De los muchos modelos de aviones que se usaron en la Primera Guerra Mundial, el Fokker Dr.1 fue uno de los más famosos. No era el único avión alemán, y ciertamente no era el mejor de los aviones durante el conflicto, pero llegó a ser famoso gracias a un hombre que se convirtió en leyenda: Manfred von Richthofen, mejor conocido como “El Barón Rojo”.

La producción del Dr.1 comenzó a mediados de 1917 cuando la necesidad de combatir al triplano británico Sopwith Camel llevó a Alemania a buscar nuevos y mejores aviones de combate. Tras varios prototipos y pruebas marcados por múltiples problemas, Reinhold Platz produjo un diseño que incorporaba nuevas tecnologías y prometía cumplir la tarea encomendada. Cuando en agosto de 1917 la fábrica Fokker entregó los primeros prototipos del avión para pruebas de combate, Richthofen aseguró que era mejor que el Sopwith, y recomendó su uso a la Luftstreitkräfte alemana.

Sin embargo, el Dr.1 no era perfecto: dado el uso de un motor rotativo, el Dr.1 era inestable en vuelo, y la maniobrabilidad siempre fue un problema. Richthofen mismo dijo del avión: *“ascendía como un mono, pero maniobraba como el demonio”*.

Algunos problemas de diseño y desempeño detuvieron la producción del Dr.1. Sólo se construyeron 320. Eventualmente, el nuevo Fokker D.VII reemplazó al Dr.1 como el mejor caza alemán.





But in the hands of gifted pilots, the Dr.1 was indeed a great tool. And it was Richtofen who took the best of it. Richtofen's fame was well deserved: he was feared and admired for his skills and is credited with 80 victories in total during the war. And he got the last 20 flying a Fokker Dr.1. His squadron, known as "The Flying Circus" for the bright colours used in the planes and the ability of the pilots when maneuvering in the air was also equipped with Dr.1s, and they got many victories too. But the Red Baron found death while flying a red Dr.1 on April 21st, 1918. Since then, his name and his airplane became icons of the WWI.

Specifications of the Fokker Dr.1

Crew: One (pilot)
Length: 5.77 m (18 ft 11 in)
Wingspan: 7.20 m (23 ft 7 in)
Height: 2.95 m (9 ft 8 in)
Wing area: 18.70 m² (201 ft²)
Empty weight: 406 kg (895 lb)
Loaded weight: 586 kg (1,292 lb)
Power plant: One Oberursel Ur.II 9-cylinder rotary engine, 82 kW (110 hp)

Performance

Maximum speed: 185 km/h (115 mph) at sea level
Stall speed: 72 km/h (45 mph)
Range: 300 km (185 mi)
Service ceiling: 6,095 m (20,000 ft)
Rate of climb: 5.7 m/s (1,130 ft/min)

Armament

Two 7.92 mm (.312 in) "Spandau" IMG 08 machine guns.

Pero en las manos de pilotos hábiles, el Dr.1 era una gran herramienta. Y fue Richtofen quien mejor lo aprovechó. La fama de Richtofen era bien merecida: era admirado y temido por sus habilidades, y se le acreditan 80 victorias confirmadas en total, de las cuales las últimas 20 fueron a bordo de un Dr.1. Su escuadrón, conocido como "El Circo Volante" por los brillantes colores usados en los aviones y las acrobacias de los pilotos, también estaba equipado con Dr.1 y también obtuvieron bastantes victorias. Pero el Barón Rojo encontró la muerte el 21 de abril de 1918 mientras volaba un Dr.1 pintado de color rojo. Desde entonces, su nombre y su avión se convirtieron en íconos de la Primera Guerra mundial.

Características del Fokker Dr.1

Tripulación: Uno (piloto)
Longitud: 5.77 m
Envergadura: 7.20 m
Altura: 2.95 m
Superficie alar: 18.70 m²
Peso vacío: 406 kg
Peso con carga: 586 kg
Planta motriz: Un motor rotatorio Oberursel Ur.II de 9 cilindros, 82 kW (110 hp)

Desempeño

Velocidad máxima: 185 km/h a nivel del mar
Velocidad de pérdida: 72 km/h
Autonomía: 300 km
Techo de servicio: 6.095 m
Trepada: 5.7 m/s

Armamento

Dos ametralladoras "Spandau" IMG 08 de calibre 7.92 mm.





Approximate scale of this model: 1:33

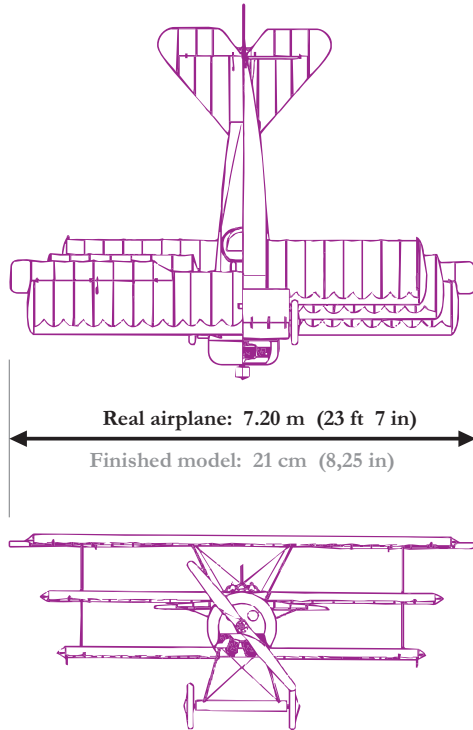

This paper model of the Fokker Dr.1 is presented at an approximate 1:33 scale. Meaning that the size of the model equals about 1/33rd of the real plane. Since this model is intended only as an approximation, scale and dimensions are not perfect as compared to the real airplane or fully detailed models.

The finished model built from the kit is approximately 21 cm X 17 cm X 9 cm (8,25 in X 6,75 in X 3,5 in). Some details may not be at scale. It can also be enlarged or reduced to other scales (see table below).

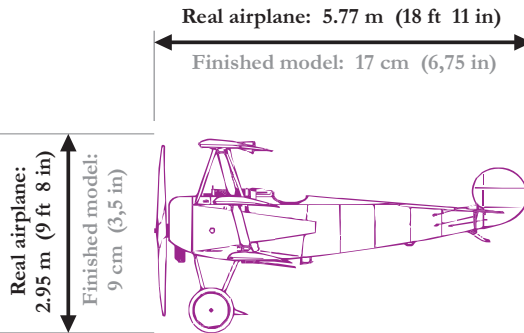

1m of the real plane is reduced to:
3.03 cm (30,3 mm) of the model.



1cm of the model represents:
33 cm of the real plane.

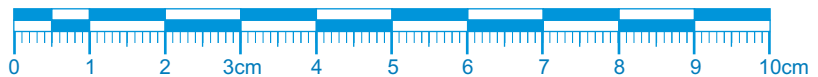

1 ft of the real plane is reduced to:
0,36 (93/256ths) inches of the model.

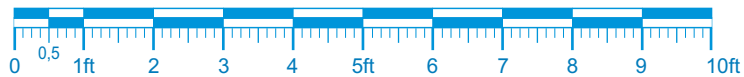

1 in of the model represents:
33 inches (2,75 ft) of the real plane.

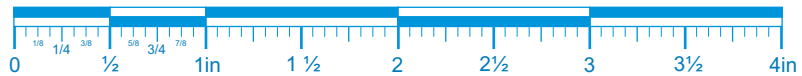

TO BUILD THIS MODEL AT OTHER SCALES

Scale	Print pages at	Built model will measure
1:16 *	206.25%	36 X 45 cm (14,2 X 17,7 in)
1:32 *	103.12%	18 X 22.5 cm (7,1 X 8,8 in)
1:48	68.75%	12 X 15 cm (4,73 X 5,91 in)
1:50	66%	11.54 X 14.4 cm (4,5 X 5,6 in)
1:72	45.83%	8 X 10 cm (3,16 X 3,9 in)
1:100	33%	7.2 X 5.77 cm (2,27 X 2,8 in)

***For scales larger than 1:33 use bigger paper**





General Instructions

Congratulations for downloading this electronic kit to build a simple paper model of the Red Baron's Fokker Dr.1. We are sure it will provide you with hours of pleasure when building and exhibiting it. If you follow the instructions given in the following pages we are sure you won't have difficulties when building it.

Patience is recommended when building any paper model. It requires time to assemble each part properly, and the glue also needs time to dry. Don't hurry or try to accelerate the process, as it will only be negative for the model.

Precision when cutting and glueing the parts will greatly improve the results. Study the instructions before cutting each part.

TOOLS

You need a set of tools to work on this paper model. Please note that the following list of tools is just a recommendation. Not all of them are needed to complete the model, but having the basic tools will help you a lot in the process.

Cutting tools:

- Scissors, useful for big parts.
- Craft knife for other parts, if needed.
- X-acto knife or scalpel, to cut out small parts or for inner cuts.
- A hole puncher, useful for cutting out holes.

Glueing tools:

- White glue (PVA) is useful for most of the parts. Be careful to apply in the proper amount, not to dampen/wrinkle the paper or to smear the ink.
- Instant glue (cyanoacrilate) is useful for the fast glueing of small pieces or to give strength to structural parts. Always use it with the proper security measures.
- Toothpicks can be used to apply glue in proper amounts with accuracy.

Felicitaciones por descargar este kit electrónico para construir un modelo de papel simple del Fokker Dr.1 del Barón Rojo. Estamos seguros que disfrutará mucho al construirlo y al exhibirlo. Si sigue las instrucciones dadas en las siguientes páginas estamos seguros que no tendrá dificultades al armarlo.

Se recomienda paciencia cuando se construye cualquier modelo de papel. Cada parte requiere tiempo para su ensamblaje adecuado, y el pegante también necesita de tiempo para secar. No se apure ni intente acelerar el proceso, pues esto sólo será negativo para el modelo.

La precisión en los cortes y en el pegado de las piezas beneficiará grandemente el resultado. Estudie las instrucciones antes de cortar cada parte.

HERRAMIENTAS

Se necesita de un conjunto de herramientas para trabajar en este modelo de papel. Por favor tenga en cuenta que la siguiente lista es tan sólo una recomendación. No se requiere de todas ellas para completar el modelo, pero tener las herramientas básicas le ayudará mucho en el proceso.

Herramientas de corte:

- Tijeras, útiles para partes grandes.
- Bisturí, para otras piezas (de ser necesario).
- Escalpelo, o bisturí X-acto ("de lanza"), para cortar pequeñas partes y para cortes internos.
- Sacabocados, útil para hacer hoyos circulares.

Herramientas de pegado:

- El pegante blanco (PVA) es útil para la mayoría de partes. Tenga cuidado al aplicarlo y no excederse, pues demasiado pegante puede emparar el papel arrugándolo, o dañando la tinta.
- El pegante instantáneo (cianoacrilato) es útil para el pegado rápido de pequeñas piezas, o para dar fuerza a partes estructurales. Siempre úselo con las medidas de seguridad adecuadas.
- Palillos de dientes. Pueden ser usados para aplicar el pegamento en cantidades adecuadas y con precisión.





Scoring tools:

- A blunt needle or an ink-less pen is useful for scoring. A sharpless cutter or a pin can also be used. A more professional tool for scoring is an embossing stylus.

Other useful tools:

- Ruler, to help with straight scores and cuts.
- Cutting mat or any other cutting surface (you can use a piece of cardboard or chipboard instead of a cutting mat).
- Pencil colours or felt markers can be used to paint the white edges of the paper and improve the appearance of the model.
- Tweezers to hold the parts while drying, to fold small tabs, or to handle small parts.
- A rod or a tube is useful to curve and curl paper/cardstock when needed.

FOLDS

There are two types of folds that are used in paper modeling.

Mountain fold is indicated with long dashed lines. You must score, and fold the paper away from you.

Valley fold is indicated with a dashed/dotted line. After scoring, fold the paper towards you.

Look at the image below for a visual explanation of the folds.

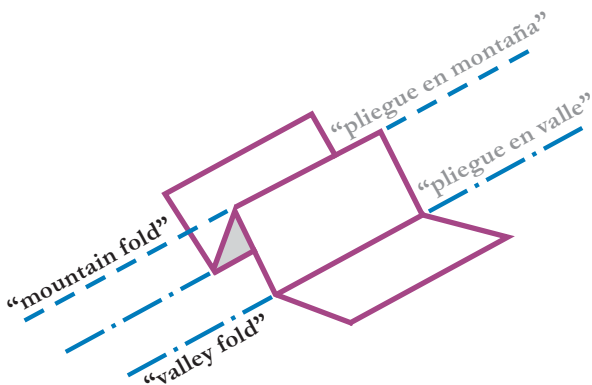

Herramientas de grafado:

- Para grafar (marcar las líneas de pliegue antes de doblarlas) se puede utilizar una aguja de punta roma, o un esfero sin tinta. También se puede utilizar un bisturí sin filo, o un alfiler. Una herramienta más profesional de grafado es el punzón de grabado usado por artesanos.

Otras herramientas útiles:

- Regla, para ayudar a los cortes y pliegues rectos.
- Tabla de corte, o cualquier otra superficie de corte (puede usar un trozo de cartón grueso o de madera).
- Lápices de colores, o marcadores, los cuales pueden usarse para pintar los bordes blancos del papel cortado y así mejorar la apariencia del modelo.
- Pinzas para sostener las partes mientras se secan, para doblar pestañas pequeñas, o para manipular partes pequeñas.
- Un tubo o trozo de madera redondeado, útil para curvar el papel/cartulina cuando se requiera.

PLIEGUES

En el modelismo en papel existen dos tipos de pliegues:

Pliegue en montaña, se indica con líneas quebradas. Debe grafar, y doblar el papel hacia fuera (lejos de usted).

Pliegue en valle, se indica con líneas largas quebradas y un punto entre los segmentos quebrados. Después de grafar, pliegue el papel sobre sí mismo (hacia usted).

Observe la imagen al costado para una explicación visual de los pliegues.





Detailed Instructions to Build This Model



IMPORTANT:

Carefully score where indicated before cutting each part from the page.

Cut each part by the middle of the outer lines.

Before starting the construction of the model read carefully the instructions to make sure you understand them.

IMPORTANTE:

Grafe cuidadosamente donde se indica antes de cortar cada parte.

Corte cada parte por el medio de las líneas exteriores.

Antes de empezar lea con atención las instrucciones para asegurarse de que las entiende correctamente.



CAUTION:

Always take the appropriate security measures when using sharp cutting objects to avoid any injuries or accidents.

Children must work always under supervision of an adult.

Work in a well-ventilated area when using some glues or paints to avoid harmful vapours.



PRECAUCIÓN:

Tome siempre las medidas de seguridad necesarias cuando utilice objetos cortantes para evitar heridas o accidentes.

Los niños deben trabajar bajo la supervisión de un adulto.

Trabaje en un área bien ventilada cuando use algunos pegamentos o pinturas que por sus vapores pueden ser nocivos para la salud.



Fold the white tabs, and glue them to close and form the fuselage. Start with the belly, and then close the top of the fuselage. After that, glue the two parts of the tail together. Finally, close the front of the nose.

Doble las pestañas blancas y aplique pegante para cerrar y formar el fuselaje. Empiece con la panza del avión, y luego cierre la parte superior. Después de esto, pegue las dos partes de la cola entre sí. Finalmente, cierre el frente de la nariz.

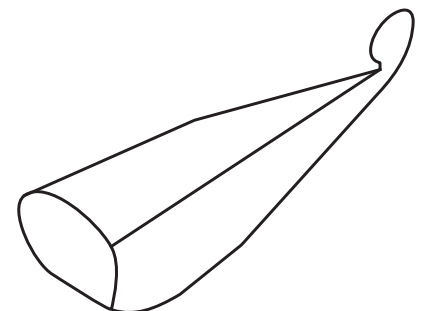
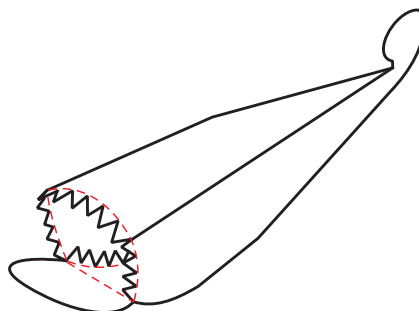
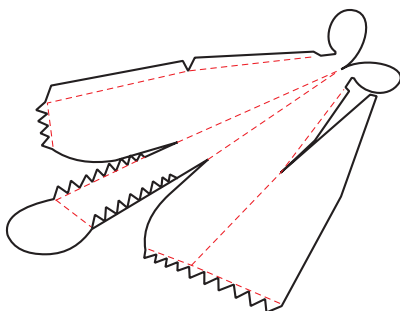



2

Fold and glue together both halves of the stabilizer.

Apply glue to the grey area to attach it to the fuselage.

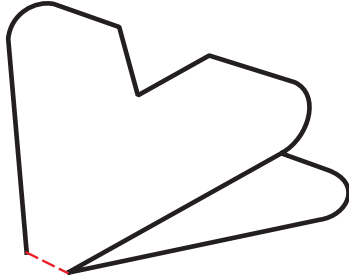

Doble y pegue juntas las dos mitades del estabilizador.

Aplique pegante a la zona gris para unirla con el fuselaje.

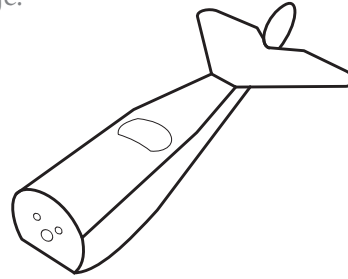

3

Fold the long white tabs, and glue them to close and form the bottom wing.

Close the wing tips, and once it's dry align and glue to the mark on the bottom of the fuselage.

The small rectangles show where to glue parts #4 & #5.

Doble las pestañas blancas largas y aplique pegante para cerrar y formar el ala inferior.

Cierre las puntas del ala, y una vez todo esté seco, aplique pegante y alinee con la marca en la parte inferior del fuselaje.

Los pequeños rectángulos indican dónde pegar las piezas #4 y #5.

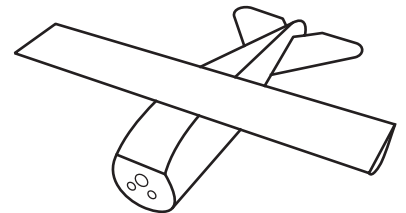
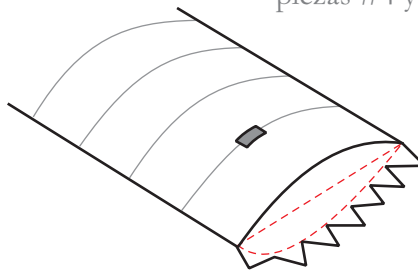
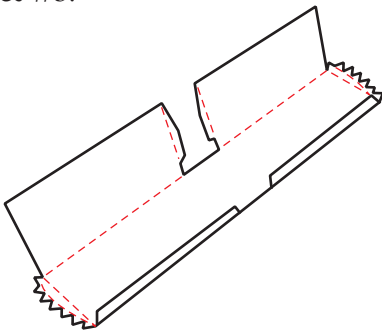

4&5

Fold the white tab and glue it to the inside of the part. Close the wing strut.

Don't glue the red tabs on the ends to themselves: fold them out and use them to glue the strut to the wings.

Look at the diagram to see how they are assembled to the wings.

Doble la pestaña blanca y péguela al interior de la parte. Cierre el soporte.

No pegue entre sí las pestañas rojas de los extremos: úselas para pegar el soporte al ala.

Observe el diagrama para ver cómo se ensamblan a las alas.

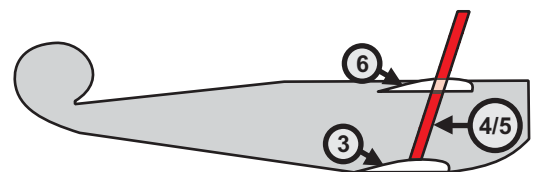
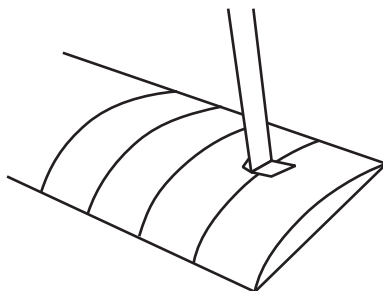
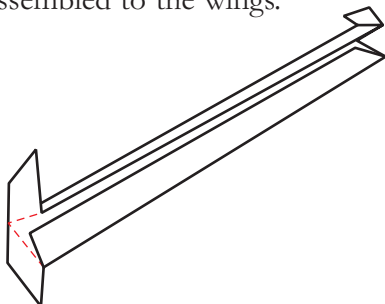



6

Cut out the four small white rectangles. Close and form the middle wing using the white tabs. Insert in the wing struts. Align and glue to the mark on the top of the fuselage.

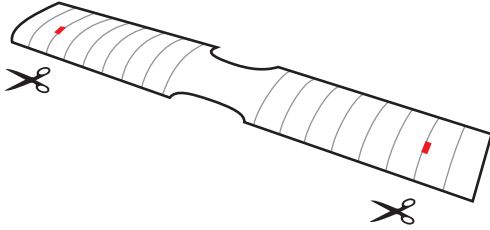

Recorte los cuatro pequeños rectángulos blancos. Cierre y forme el ala media usando las pestañas blancas. Inserte en la columna de las alas. Alinee y aplique pegante según indica la marca en la parte superior del fuselaje.

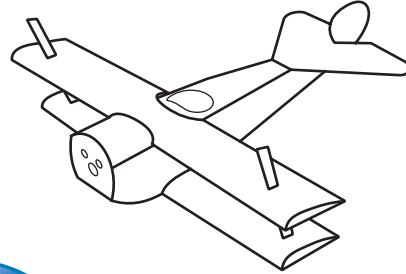

7&8

Fold by the middle, and then glue both halves. Don't apply glue to the small tabs on the ends: they will be glued afterwards to the fuselage and top wing. Use the symbol to glue it to the correct spot. Be careful to keep the angle as shown in the diagram. Follow the same procedure with the other wing strut.

Pliegue por la mitad, luego pegue la pieza sobre sí misma. No aplique pegante en las pestañas pequeñas de los extremos: se usarán para pegar la pieza al fuselaje y al ala superior. Use el símbolo para ubicarla en el lugar correcto. Tenga cuidado de mantener el ángulo como se muestra en el diagrama. Siga el mismo procedimiento con el otro soporte del ala.

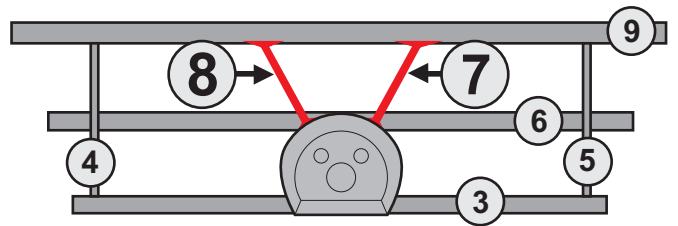
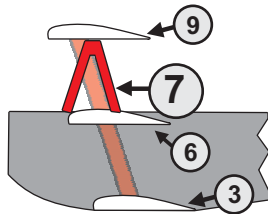
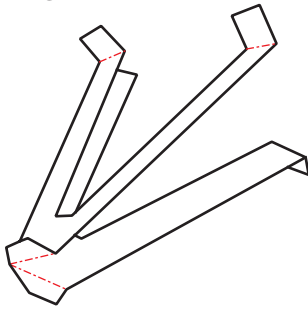

9

Use the white tabs to glue and close the upper wing the same way you did with the other two wings. Close the wing tips, and glue the wing to the struts. The small rectangles and the symbols show where to glue the wing struts.

Use la pestaña blanca para pegar y cerrar el ala superior de la misma manera como hizo con las dos alas anteriores. Cierre los extremos del ala y péguela a los soportes. Los pequeños rectángulos y los símbolos indican dónde pegar los soportes de las alas.

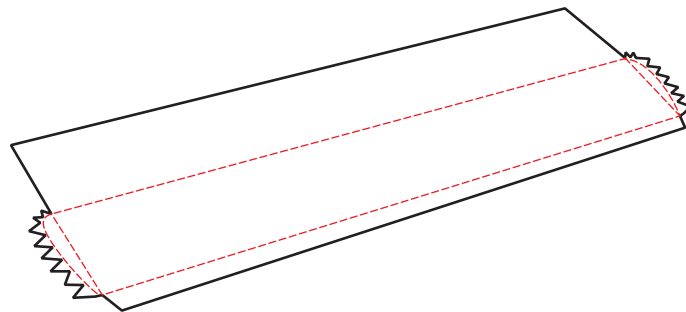



10 & 11

Assemble the landing gear struts the same way you did with the top wing struts. The symbols help to glue the parts in the correct spots. Be careful with the angle.

Ensamble los soportes del tren de aterrizaje de la misma manera que lo hizo con los soportes del ala superior. Los símbolos sirven como guía para pegar las piezas en los puntos adecuados. Tenga cuidado con el ángulo.

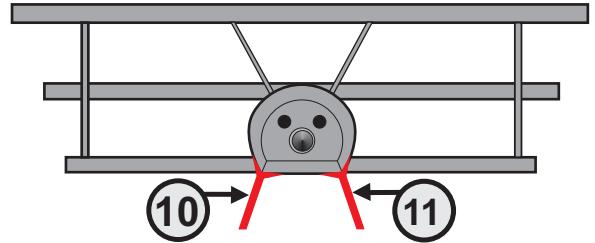
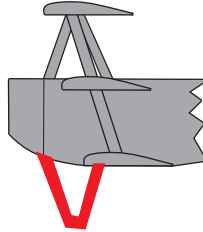
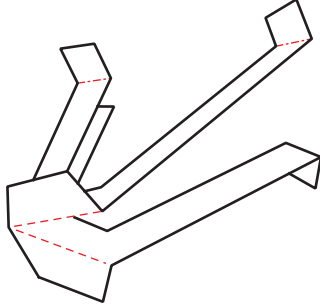

12

Cut out the white circles before assembling the part. Close the part the same way as the wings. The axle will be inserted here.

Recorte los círculos blancos antes de armar la pieza. Arme la pieza del mismo modo que las alas. Aquí se insertará después el eje.

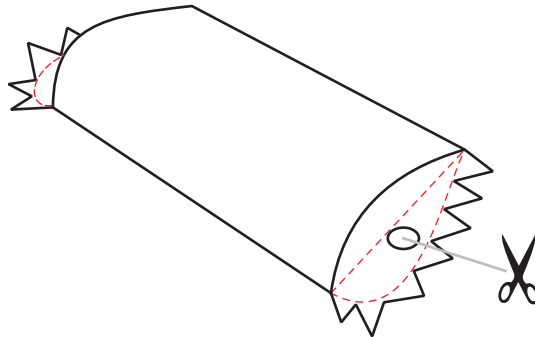

13

This is the axle of the wheels. Use the white tab to close it, and then insert the axle through the holes of part # 10. Use the red tabs in the ends to attach it to the wheels after inserting it in part #10.

Este es el eje de las ruedas. Use la pestaña blanca para cerrarlo. Luego insértelo a través de los huecos practicados en la pieza # 10. Use las pestañas rojas en los extremos para pegarlo a las ruedas después de insertarlo en la pieza #10.

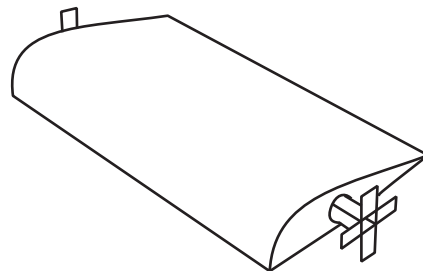
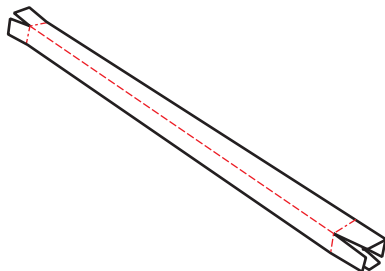



14 & 15

Close the wheels using the white tabs, and then glue them to the ends of the axle (part #11).

Cierre las ruedas usando las pestañas blancas y luego péguelas a los extremos del eje (pieza #11).

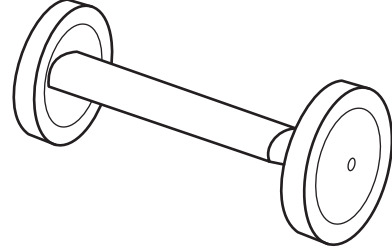
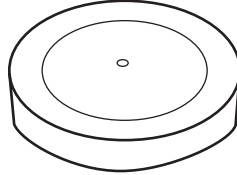
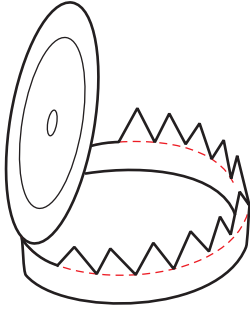

16

Cut the propeller, fold it and glue it to close it. Glue it to the front of the fuselage.

Corte la hélice, dóblela y péguela para cerrarla. Después péguela al frente del fuselaje.

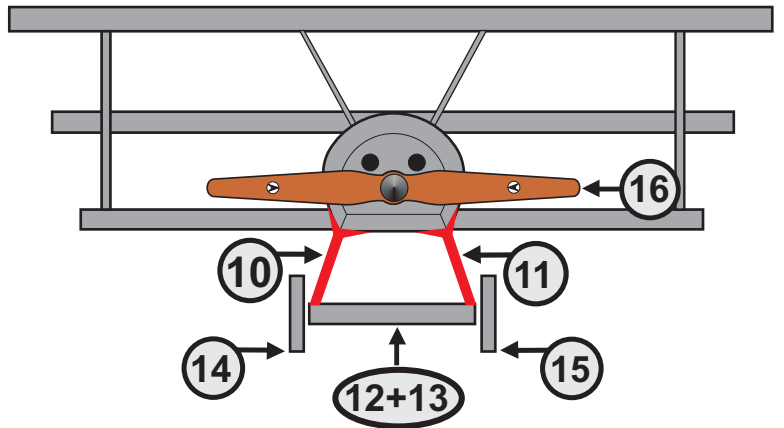
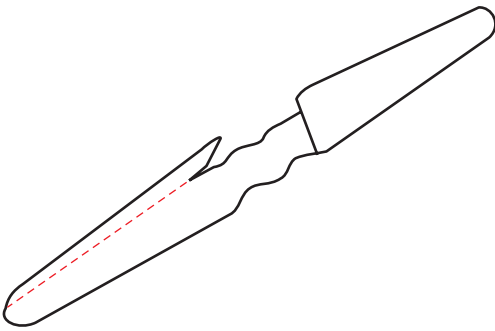

The paper model of the Fokker Dr.1 is finished.

El modelo en papel del Fokker Dr.1 está terminado.



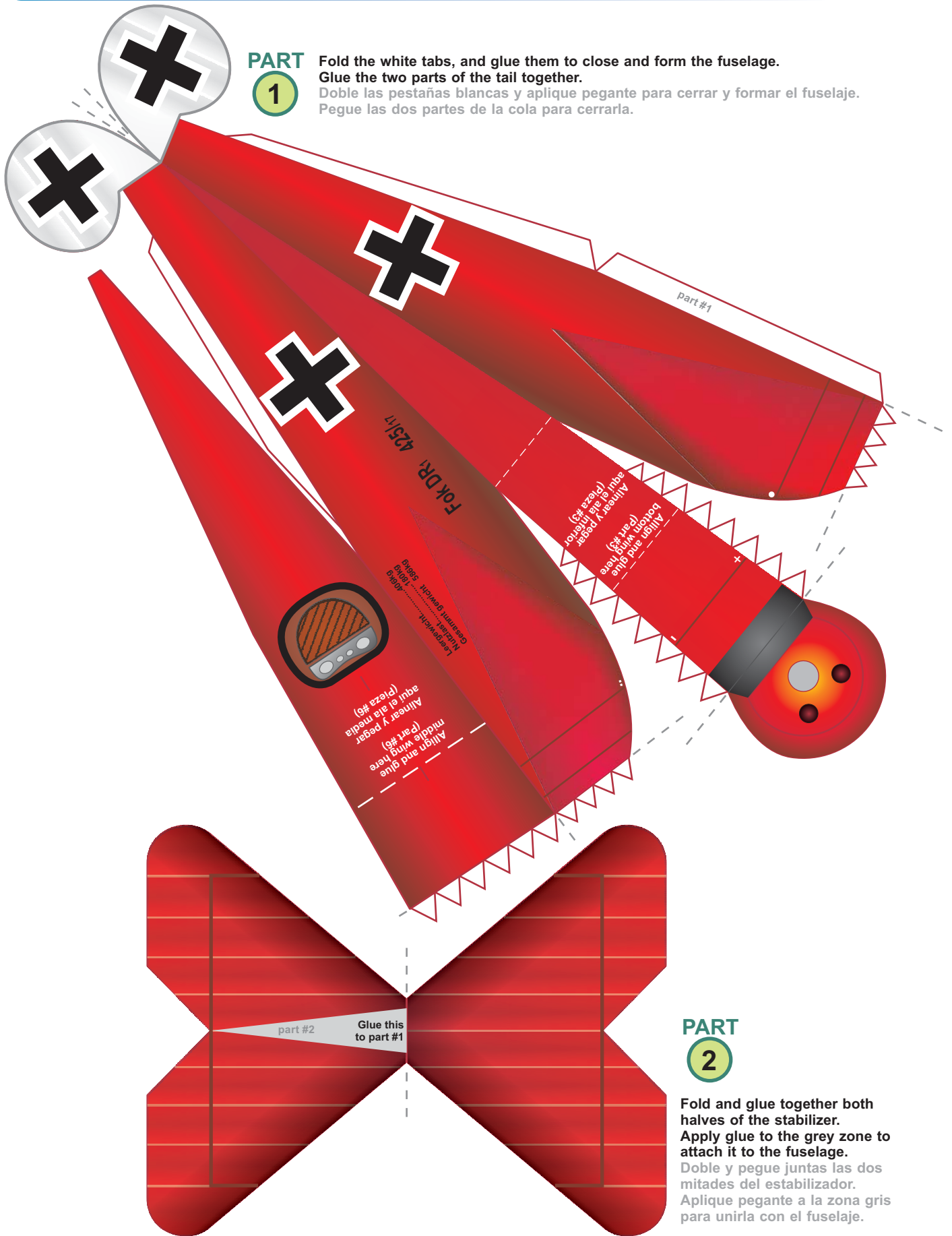

PART
1

Fold the white tabs, and glue them to close and form the fuselage.
Glue the two parts of the tail together.
Doble las pestañas blancas y aplique pegante para cerrar y formar el fuselaje.
Pegue las dos partes de la cola para cerrarla.

PART
2

Fold and glue together both halves of the stabilizer.
Apply glue to the grey zone to attach it to the fuselage.
Doble y pegue juntas las dos mitades del estabilizador.
Aplique pegante a la zona gris para unirla con el fuselaje.





PART 3 Fold the long white tabs, and glue them to close and form the bottom of the fuselage. The small rectangles show where to glue parts #4 & #5.

3

Doble las pestañas blancas largas y aplique pegante para cerrar y formar el ala inferior. Aplique pegante y alinee con la marca en la parte inferior del fuselaje. Los pequeños rectángulos muestran donde pegar las piezas #4 y #5.

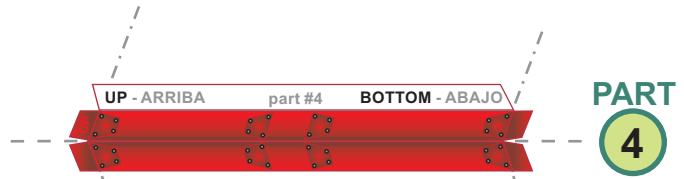

PART 4

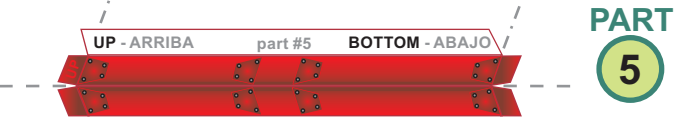

PART 5

Fold the white tab and glue it to the inside of the part. Close the wing strut. Don't glue the red tabs on the ends to themselves: fold them out and use them to glue the strut to the wings. Look at the diagram to see how they are assembled to the wings. Doble la pestaña blanca y péguela al interior de la parte. Cierre el soporte. No pegue entre sí las pestañas rojas de los extremos: úselas para pegar el soporte al ala. Observe el diagrama para ver cómo se ensamblan a las alas.

Fold out.
Doble hacia afuera.

Fold out.
Doble hacia afuera.

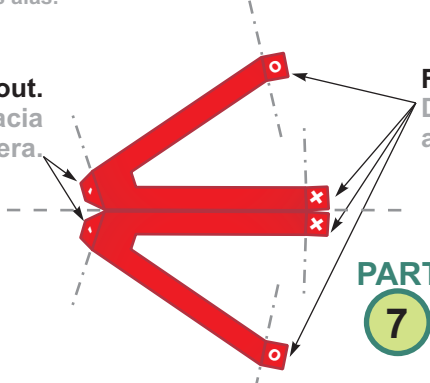

Fold by the middle, and then glue both halves. Don't apply glue to the small tabs on the ends: they will be glued afterwards to the fuselage and top wing. Use the symbol to glue it to the correct spot. Be careful to keep the angle as shown in the diagram.

Pliegue por la mitad, y pegue las dos mitades. No aplique pegante en las pestañas pequeñas de los extremos: se usarán para pegar la pieza al fuselaje y al ala superior. Use el símbolo para ubicarla en el lugar correcto. Tenga cuidado de mantener el ángulo como se muestra en el diagrama.

PART 8

Follow the same procedure with the other wing strut. Siga el mismo procedimiento con el otro soporte del ala.

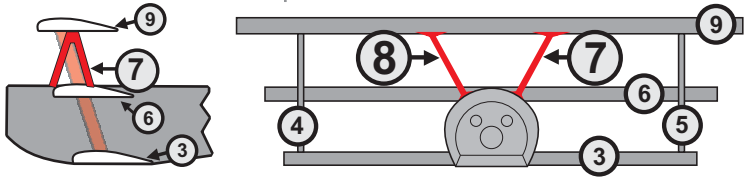
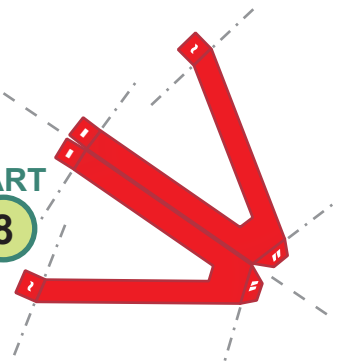



PART
6

Cut out the four small white rectangles. Close and form the middle wing using the white tabs. Insert in the wing struts. Align and glue to the mark on the top of the fuselage.

Recorte los cuatro pequeños rectángulos blancos. Cierre y forme el ala media usando las pestañas blancas. Inserte en la columna de las alas. Alinee y aplique pegante según indica la señal en la parte superior del fuselaje.

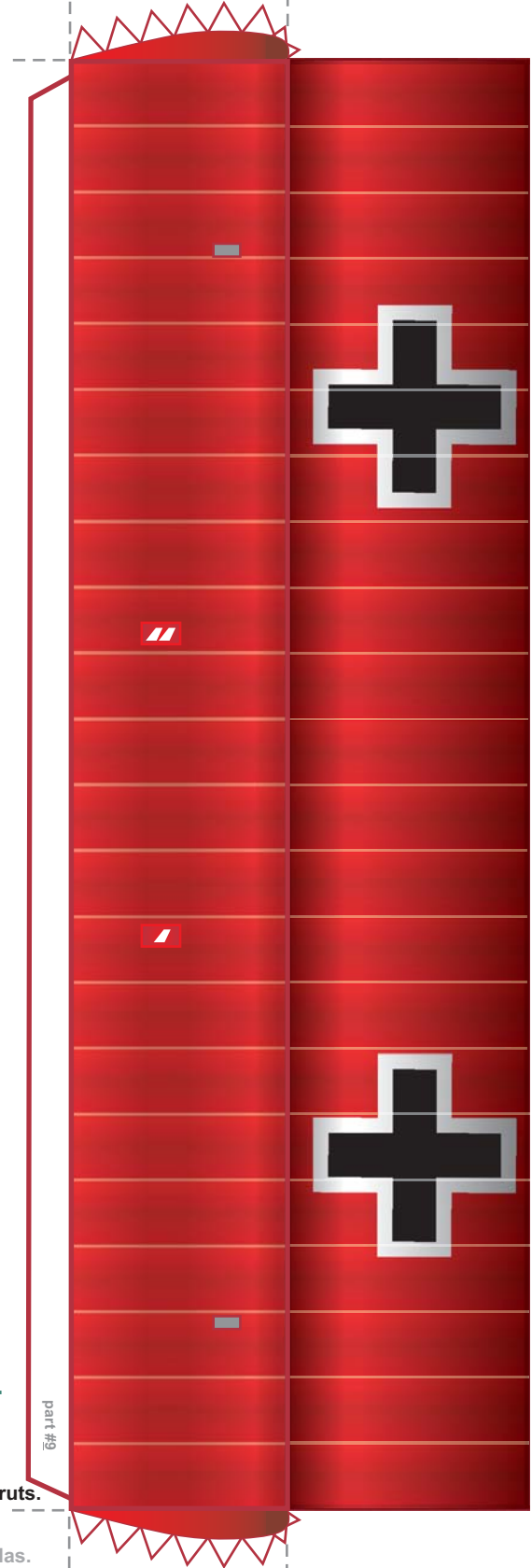
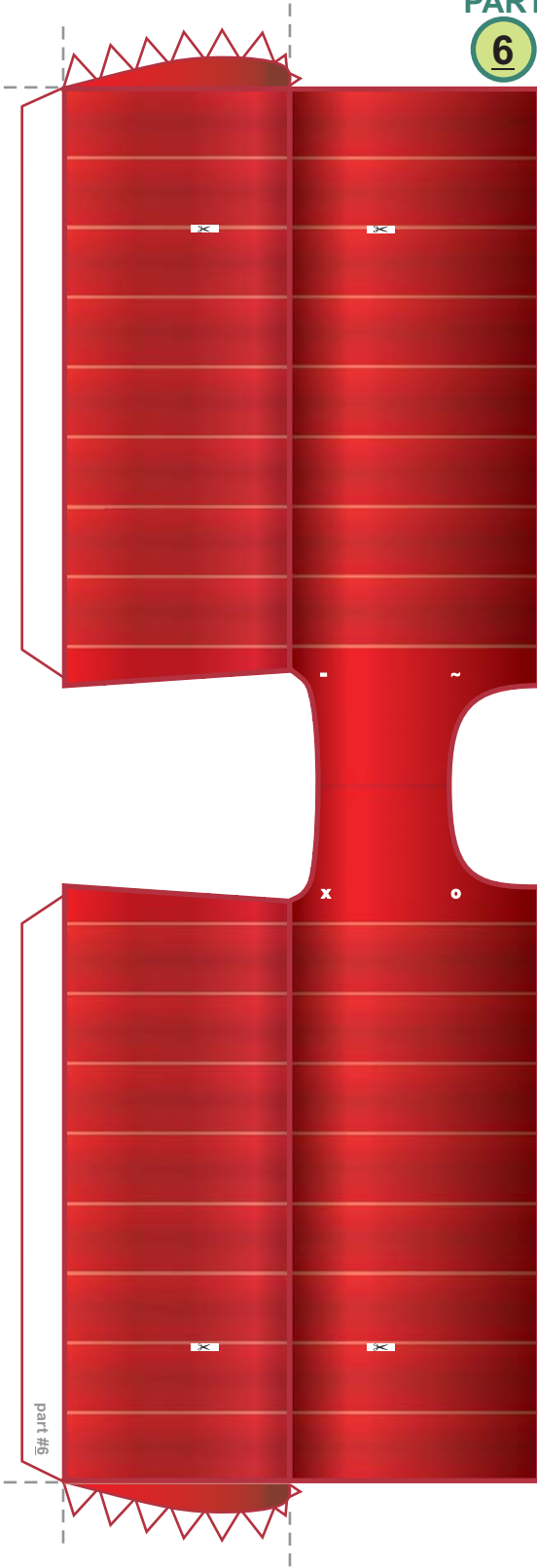

PART
9

Use the white tabs to glue and close the upper wing. Close the wing tips, and glue the wing to the struts. The small rectangles and the symbols show where to glue the wing struts. Use la pestaña blanca para pegar y cerrar el ala superior. Cierre los extremos del ala y péguela a los soportes. Los pequeños rectángulos y los símbolos indican dónde pegar los soportes de las alas.



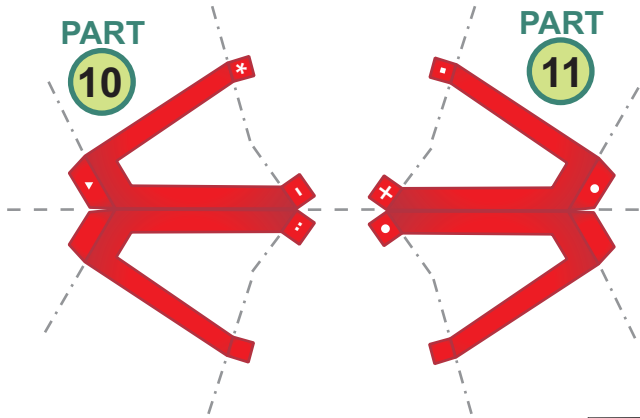

Assemble the landing gear struts the same way you did with the top wing struts. The symbols help to glue the parts in the correct spots. Be careful with the angle.

Ensamble los soportes del tren de aterrizaje de la misma manera que lo hizo con los soportes del ala superior. Los símbolos sirven de guía para pegar las piezas en los puntos adecuados. Tenga cuidado con el ángulo.

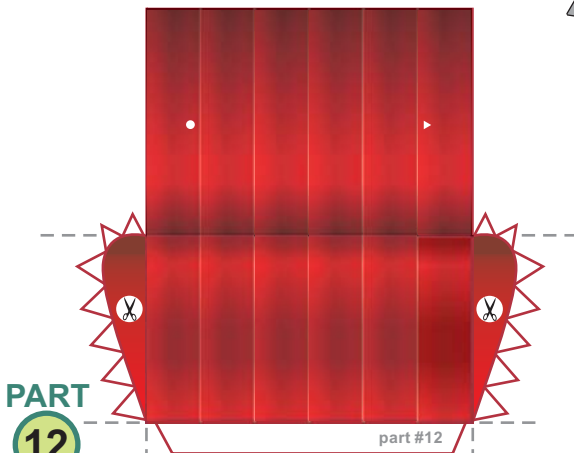
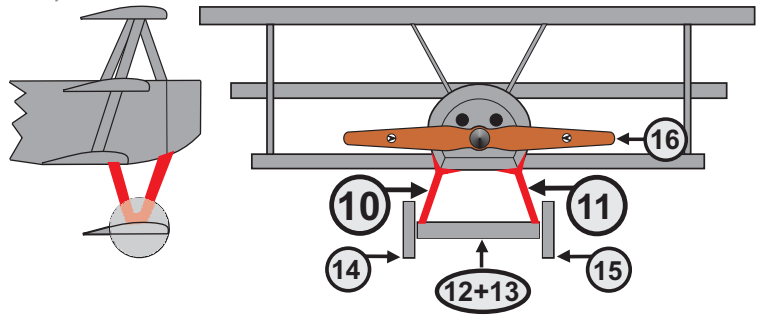

PART
12

Cut out the white circles before assembling the part. Close the part the same way as the wings. The axle will be inserted here.

Recorte los círculos blancos antes de armar la pieza. Arme la pieza del mismo modo que las alas. Aquí se insertará después el eje.

PART



This is the axle of the wheels. Use the white tab to close it, and then insert the axle through the holes of part # 10. Use the red tabs in the ends to attach it to the wheels after inserting it in part #10.

Este es el eje de las ruedas. Use la pestaña blanca para cerrarlo. Luego insértelo a través de los huecos practicados en la pieza # 10. Use las pestañas rojas en los extremos para pegarlo a las ruedas después de insertarlo en la pieza #10.

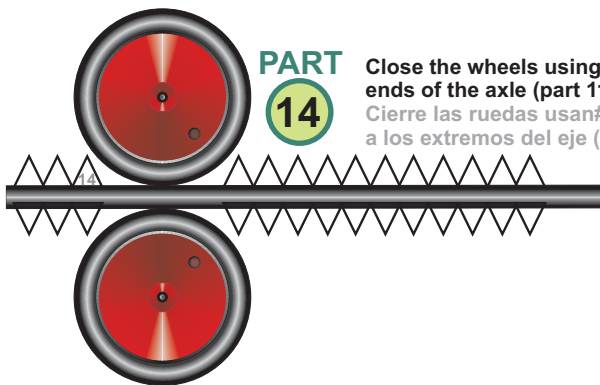

PART
14

Close the wheels using the white tabs, and then glue them to the ends of the axle (part 11).

Cierre las ruedas usando las pestañas blancas y luego péguelas a los extremos del eje (pieza #11).

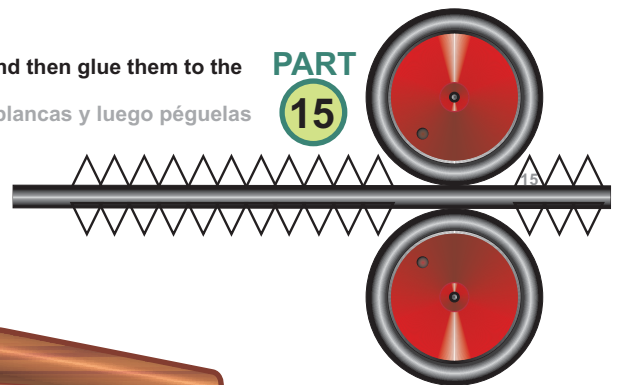

PART
15

PART
16

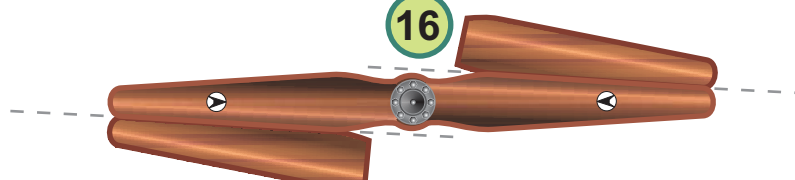

Cut the propeller, fold it and glue it to close it. Glue it to the front of the fuselage.

Corte la hélice, dóblela y péguela para cerrarla. Después péguela al frente del fuselaje.

END
FIN

